

MATERIAL: SEE B/M  
 DRAWN: F/WK CHECKED:  
 SCALE: NONE DATE: 03/10/08



TLA, BODY  
 W/ WN FLANGE

DIMS VALID FOR CL150 FLANGES ONLY

FILE NO.: E400-04.DWG

Section: E400  
 Bulletin: E400 04  
 Date: 3/10/08  
 Supersedes: NEW

**NOTE: BOLT HOLES STRADDLE CENTERLINES**

THIS DRAWING AND ALL INFORMATION ON IT IS THE PROPERTY OF JACOBRY-TARBOX, DIVISION OF THE CLARK-RELANCE CORPORATION. IT IS CONFIDENTIAL AND IS GIVEN TO YOU FOR A LIMITED PURPOSE AND MUST BE RETURNED UPON REQUEST. NEITHER THIS DRAWING NOR ANY PART OF IT NOR ANY INFORMATION CONCERNING IT MAY BE COPIED, EXHIBITED OR FURNISHED TO OTHERS NOR MAY PHOTOGRAPHS BE TAKEN OF ANY ARTICLE FABRICATED OR ASSEMBLED FROM THIS DRAWING WITHOUT CONSENT OF THE CLARK-RELANCE CORPORATION.

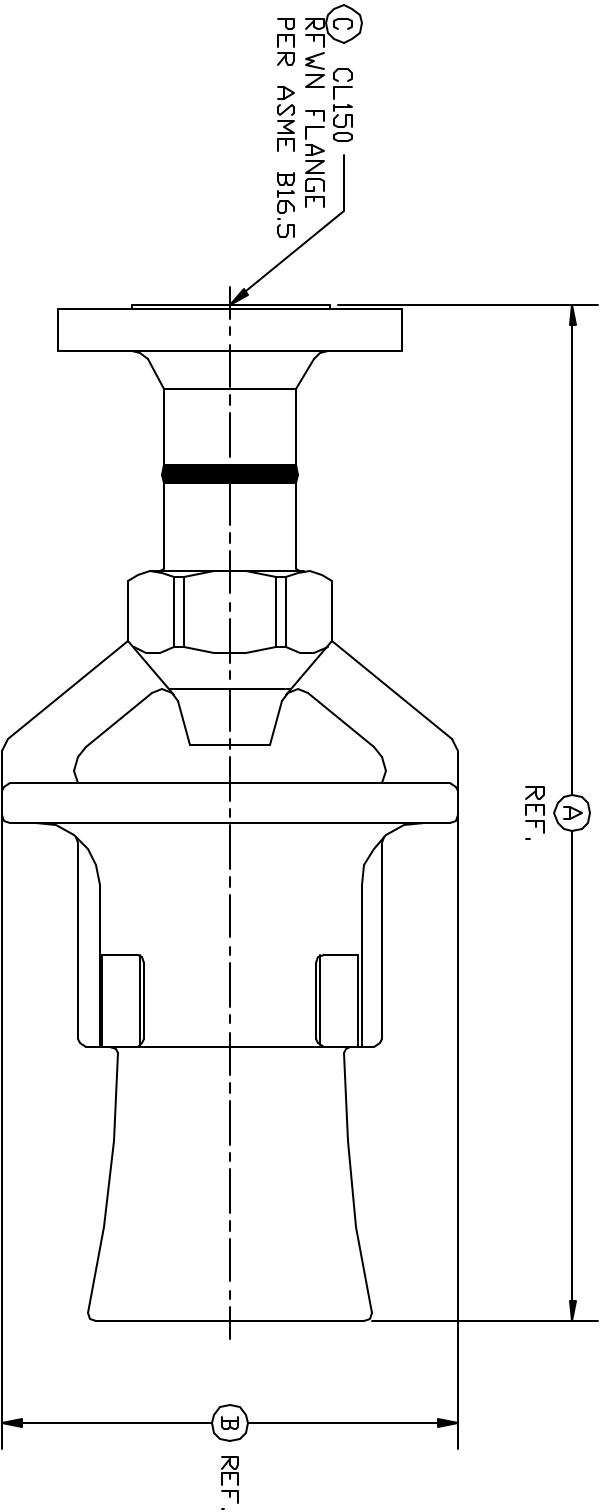

SIZE	PART No.	MATERIAL	A	B	C
3/8"	TB-3922-T10FLG1	316LSS	7.75	3.50	1/2"
	TB-3923-A27FLG1	CARBON STEEL			
3/4"	TB-3923-T10FLG1	316LSS	8.94	3.88	3/4"
	TB-3924-A27FLG1	CARBON STEEL			
1-1/2"	TB-3924-T10FLG1	316LSS	12.75	5.54	1-1/2"
	TB-3925-A27FLG1	CARBON STEEL			
2"	TB-3925-T10FLG1	316LSS	17.44	7.68	2"
	TB-3926-A27FLG1	CARBON STEEL			
3"	TB-3926-T10FLG1	316LSS	25.25	11.73	3"

- NOTES:
1. DIMENSION "B" IS THE O.D. OF THE FLANGE FOR 3/8" & 3/4" UNITS
  2. 3/8" UNITS AVAILABLE IN 316LSS ONLY